

JVC

SERVICE MANUAL

COMPACT VHS CAMCORDER

GR-SXM75ED

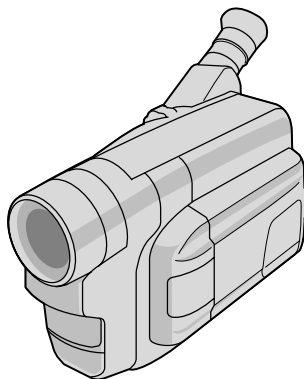

S VHS VHS
PAL
625

Super VHS
Super VHS ET

Regarding service information other than these sections, refer to the GR-SXM26EG service manual (No. 86543). Also, be sure to note important safety precautions provided in the service manual.

SPECIFICATIONS

Camcorder

General

Format	: S-VHS/VHS PAL standard
Power source	: DC 6.0 V ---
Power consumption	
LCD monitor* off, viewfinder on	: 4.1 W
LCD monitor* on, viewfinder off	: 4.6 W
LCD monitor* on, viewfinder on	: 5.1 W
Video light	: 3.0 W
Signal system	: PAL-type
Video recording system	
Luminance	: FM recording
Colour	: Converted sub-carrier direct recording Conforms to VHS standard
Cassette	: S VHS / VHS cassette
Tape speed	
SP	: 23.39 mm/sec.
LP	: 11.70 mm/sec.
Recording time (max.)	
SP	: 60 minutes
LP	: 120 minutes (with EC-60 cassette)
Operating temperature	: 0°C to 40°C
Operating humidity	: 35% to 80%
Storage temperature	: -20°C to 50°C
Weight	: Approx. 940 g
Dimensions (W x H x D)	: 198 mm x 119 mm x 99 mm (with the LCD monitor* closed and with the viewfinder fully tilted downward)
Pickup	: 1/4" format CCD
Lens	: F1.6, f = 3.9 mm to 62.4 mm, 16:1 power zoom lens with auto iris and macro control, filter diameter 40.5 mm
Viewfinder	: Electronic viewfinder with 0.55" colour LCD
White balance adjustment	: Auto/Manual adjustment
LCD monitor	: 2.5" diagonally measured, LCD panel/TFT active matrix system
Speaker	: Monaural

Connectors

JLIP	: ϕ 3.5 mm, 4-pole, mini-head jack (compatible with RC-5325 plug)
Video	: 1 V (p-p), 75 Ω unbalanced, analogue output (via Video output connector)
Audio	: 300 mV (rms), 1 k Ω analogue output (via Audio output connector)
S-Video	: Y: 1 V (p-p), 75 Ω , analogue output C: 0.29 V (p-p), 75 Ω , analogue output

AC Power Adapter/Charger AA-V16ED

Power requirement	: AC 110 V to 240 V \sim , 50 Hz/60 Hz
Power consumption	: 23 W
Output	
Charge	: DC 8.5 V --- , 1.3 A
VTR	: DC 6.3 V --- , 1.8 A
Charging system	: Constant current, peak detection, timer controlled
Dimensions (W x H x D)	: 125 mm x 42 mm x 68 mm
Weight	: Approx. 270 g

Cassette Adapter C-P7U

Dimensions (W x H x D)	: 188 mm x 25 mm x 104 mm
Weight	: Approx. 240 g
Accessory	: "R6 (AA)"-size battery x 1

Optional Accessories

- Battery Packs BN-V12U, BN-V20U, BN-V856U
- Car Battery Charger BH-V3E
- Compact S-VHS (**S VHS**) Cassettes SE-C45/30
- Compact VHS (**VHS**) Cassettes EC-60/45/30
- Remote Control Unit RM-V700U
- Active Carrying Bag CB-V7U

Some accessories are not available in some areas. Please consult your nearest JVC dealer for details on accessories and their availability.

Specifications shown are for SP mode unless otherwise indicated.
E & O.E. Design and specifications subject to change without notice.

TABLE OF CONTENTS

DIFFERENT TABLE	1 to 2
4. CHARTS AND DIAGRAMS	
4.1 VF/MTIF SCHEMATIC DIAGRAM	4-1
4.2 BOARD INTERCONNECTIONS	4-2
5. PARTS LIST	
5.1 PACKING AND ACCESSORY ASSEMBLY <M1>	5-1
5.2 FINAL ASSEMBLY <M2>	5-3
5.3 ELECTRONIC VIEWFINDER ASSEMBLY <M4>	5-6
5.4 ELECTRICAL PARTS LIST	
MAIN BOARD ASSEMBLY <01>	5-7
BL BOARD ASSEMBLY <06>	5-12
VF BOARD ASSEMBLY <10>	5-12

The following table indicate main different points between models GR-SXM26EG and GR-SXM75ED.

ITEM	MODEL	GR-SXM26EG	GR-SXM75ED
AC POWER ADAPTER CHARGER		AA-V16EG	AA-V16ED
BODY COLOR		Pearl Gray	Light Gold
CASS.ADAPTER ASSY		Optional	Provided
"CONNECTOR,CABLE ADAPTER"		Provided	Optional
REMOTE CONTROLLER		Optional	Provided
TAPE SPEED		SP	SP/LP
VIEW FINDER		Black/White	Color
ZOOM		50X	450X

The following table indicate different parts number between models GR-SXM26EG and GR-SXM75ED.

PACKING AND ACCESSORY ASSEMBLY <M1> Note: As for IB (INSTRUCTIONS), refer to sec.5.

REF NO.	ITEM	MODEL	GR-SXM26EG	GR-SXM75ED
2	PACKING CASE		LY31143-011A	LY31561-064A
3	CUSHION		LY31184-001A	LY31563-001A
△ 6	LI BATTERY		PECA0903	PECA0903, X2
7	WARRANTY CARD		BT-54013-1	BT-59007-2
9	SHEET(MINITEL)		* PU36564	—
13	CONNECTOR, CABLE ADAPTER		PEMC1000-01-02	—
16	REMOTE CONTROLLER		—	YQ20932A
18	SHEET (C.FILTER)		* LYT0486-015A	—
19	SHEET (ATT.)		—	LYT0569-004A
21	GUARANTY CARD		—	BT-59012-1
24	BATTERY, CASS.ADAPTER, R6(AA)		Not used	Used
25	CASS. ADAPTER ASSY		—	YQ31963B-3

Note: Mark — is not used. Mark * reference model was also changed.

FINAL ASSEMBLY <M2>

REF NO.	ITEM	MODEL	GR-SXM26EG	GR-SXM75ED
△ 101	LOWER CASE ASSY		* LY12122-036A	LY12122-036B
△ 106	FRONT COVER ASSY		LY10124-043A	LY10124-062A
107	CASS.COVER(M)ASSY		LY10131-020A	LY10131-030B
107C	SHIELD SHEET		—	LY40559-001A
108	UPPER CASE(M)		LY10133-002C	LY10133-006B
110	TOP COVER		LY10129-081A	LY10129-0C2A
113	OPERATION UNIT		LY10120-037A	LY10120-057A
152	CASSETTE HOUSING ASSY		* YQ31752H-31	YQ31752H-34

OPTICAL BLOCK SECTION

REF NO.	ITEM	MODEL	GR-SXM26EG	GR-SXM75ED
252	CCD BASE ASSY		LYH40018-004A	LYH40018-003A
255	OP LPF		LY41370-001A	LY41756-001A
256	CCD SPACER		LY20086-001A	LY20346-001A

MECHANISM ASSEMBLY <M3>

REF NO.	ITEM	MODEL	GR-SXM26EG	GR-SXM75ED
468	DRUM ASSY		YDV2094A	YDV2095A

ELECTRONIC VIEWFINDER ASSEMBLY <M4>

REF NO.	ITEM	MODEL	GR-SXM26EG	GR-SXM75ED
△ 300	E.VF ASSY		LY20307-005A	—
△ 350	E.VF ASSY		—	LYH20158-001A

MONITOR ASSEMBLY <M5>

REF NO.	ITEM	MODEL	GR-SXM26EG	GR-SXM75ED
△ 500	MONITOR ASSY		LYH20126-005A	LYH20126-024C
△ 502	COVER(MONI)ASSY		LY20482-005A	LY20482-015A
502A	WINDOW		LY31295-005A	LY31295-012A
503	COVER(U.HINGE)		LY20333-004A	LY20333-008A
514	LCD MODULE		* QLD0082-001	QLD0130-001

MAIN BOARD ASSEMBLY <01>

REF NO.	ITEM	MODEL	GR-SXM26EG	GR-SXM75ED
PW	MAIN BOARD ASSY		YB10271EB-04	YB10271ER-04

Note: Mark — is not used. Mark * reference model was also changed.

BL BOARD ASSEMBLY <06>

REF NO.	ITEM	MODEL	GR-SXM26EG	GR-SXM75ED
PW2	BL BOARD ASSY		–	YB20867B2

VF BOARD ASSEMBLY <10>

REF NO.	ITEM	MODEL	GR-SXM26EG	GR-SXM75ED
PW1	VF BOARD ASSY		–	YB20867B1

E.VF BOARD ASSEMBLY <50>

REF NO.	ITEM	MODEL	GR-SXM26EG	GR-SXM75ED
PW	E.VF BOARD ASSY		PTY20307-601	–

SECTION 6 AC POWER ADAPTER**CABINET ASSEMBLY <MA>**

REF NO.	ITEM	MODEL	GR-SXM26EG	GR-SXM75ED
⚠ 3	POWER CORD		YQ10531-006	PTY10067-037

Note: Mark – is not used.

